

MAX. PAYLOAD: 3.1 tonnes MAX. LIFT HEIGHT: 7 metres

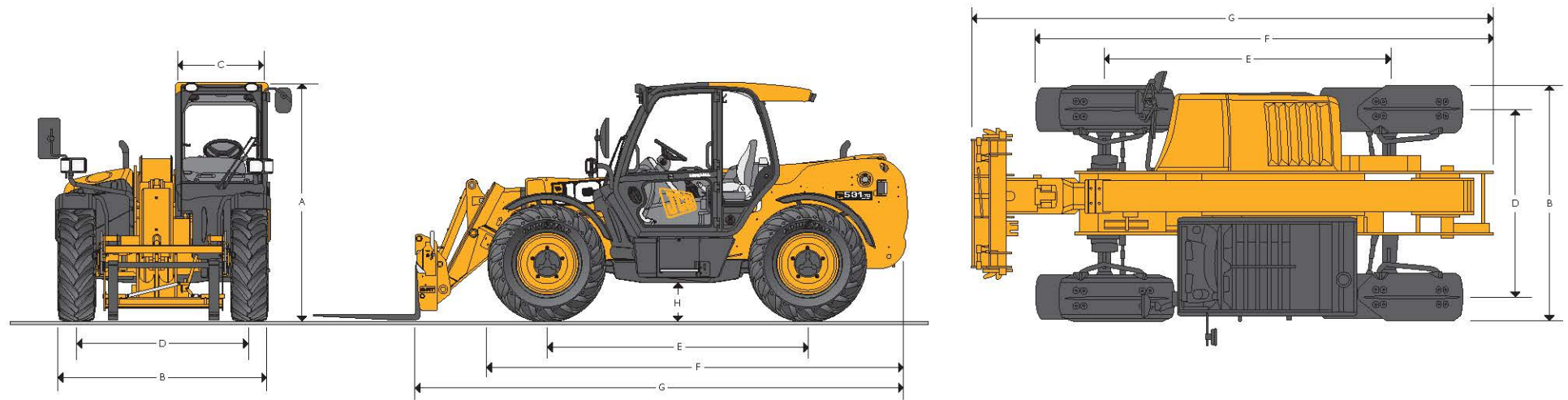

STATIC DIMENSIONS

Machine model	531-70
	m
A Overall height	2.49
B Overall width (over tyres)*	2.23
C Inside width of cab	0.94
D Front track	1.81
E Wheelbase	2.75
F Overall length to front tyres	4.38
G Overall length to front carriage	4.99

Machine model	531-70
	m
H Ground clearance	0.40
Outside turn radius (over tyres)	3.7
Carriage roll back angle	degrees 42.6
Carriage dump angle	degrees 37.5
Weight – Fixed	kg 7060
Tyres	15.5/80-24

*Dependant upon tyre specified.

LIFT PERFORMANCE – 531-70

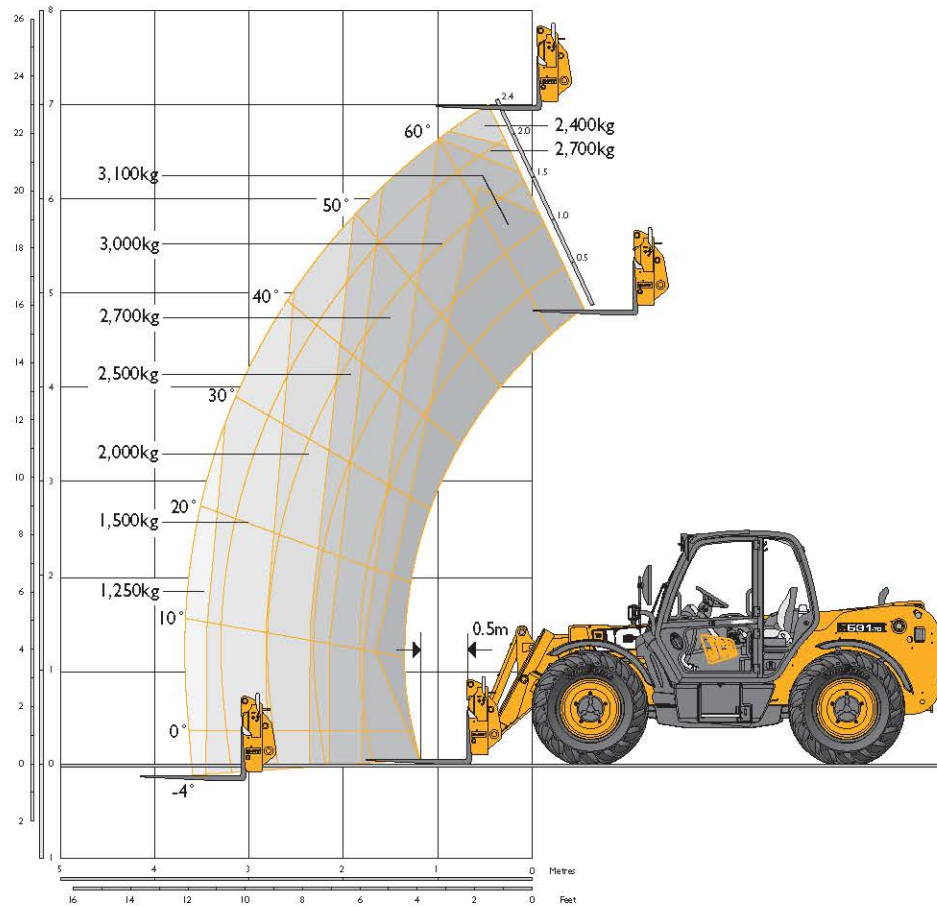

LIFT PERFORMANCE – 531-70

Machine Model		531-70
Maximum lift capacity	kg	3100
Lift capacity to full height	kg	2400
Lift capacity at full reach	kg	1250
Lift height	m	7.0
Reach at maximum lift height	m	0.48
Maximum forward reach	m	3.7
Reach with 1 tonne load	m	3.7
Placing height	m	6.3

Complies with stability test EN 1459 Annex B.

ENGINE

Latest technology and advanced design provides low fuel consumption, reduced noise, high torque and power output, total reliability and minimal maintenance. Two stage, dry type air filter with primary and safety elements. Territory dependent.

		Standard	Standard	Standard	Option	Option	Option
		Stage II	Stage III	Stage IIIb	Stage II	Stage III	Stage IIIb
Engine standard		Stage II	Stage III	Stage IIIb	Stage II	Stage III	Stage IIIb
Manufacturer		JCB	JCB	JCB	JCB	JCB	JCB
Displacement	ltr	4.4	4.4	4.4	4.4	4.4	4.4
No. of cylinders		4	4	4	4	4	4
Bore size	mm	103	103	103	103	103	103
Stroke	mm	132	132	132	132	132	132
Aspiration		Naturally aspirated	Turbo	Turbocharged cooled	Turbo	Turbocharged cooled	Turbocharged cooled
Power rating							
Power @ 2200rpm	kW (HP)	63 (85)	63 (85)	55 (75)	74.2 (100)	74.2 (100)	81 (109)
Torque rating							
Torque @ 1200rpm	Nm	320	362	–	–	–	–
Torque @ 1300rpm	Nm	–	–	400	425	440	512

TRANSMISSION

JCB powershift transmission incorporating torque converter, bevel box and a 4 speed powershift gearbox in one resiliently mounted unit. A combined steering column mounted switch incorporating directional control and 4 forward and 4 reverse powershift gears. Travel speed 29kph (18mph) 33kph (20mph when 2/4WD select is specified).

Front and rear drive axles: JCB epicyclic hub reduction drive/steer axles with Max-Trac torque proportioning differentials. Permanent 4 wheel drive.

BRAKES

Service brakes: Servo-assisted, hydraulically activated, self-adjusting, oil-immersed in-board high back-off multi-disc type on front axle.

Parking brake: Hand operated disc brake on output of gearbox.

BOOM AND CARRIAGE

Boom is manufactured from high tensile steel.

Low maintenance, hard wearing pads.

JCB Q-fit self-levelling carriage with lever operated pin locking accepts pallet forks and a wide range of attachments.

One boom end auxiliary hydraulic service fitted as standard.

SAFETY CHECK VALVES

Fitted to carriage tilt, telescopic and boom lift rams.

SERVICE CAPACITIES

Fuel tank	litres	146
Hydraulic tank	litres	113
Coolant	litres	23

HYDRAULICS

Gear pump with suction strainer and filter.

Operating system pressure	bar	241
Main Hydraulics	ltrs/min	82
Hydraulic Cycle Times		Seconds
Boom raise		7.2
Boom lower		5.4
Extend		6.8
Retract		5.0
Bucket dump		3.5
Bucket crowd		2.9

ELECTRICS

12 v negative earth. 95 AH battery, 95 amp alternator. Full road lighting. Reversing light. Direction indicators. Hazard warning. Reverse alarm.

CAB

Quiet safe and comfortable cab conforms to ROPS ISO 3471 and FOPS ISO 3449. Tinted glass all round. Laminated roof screen. Roof bars, front, rear and roof screen wash/wipe and heater/screen demister. Opening rear window. Audio-visual warning system for coolant temperature, engine oil pressure, air cleaner, battery charge, transmission oil temperature and pressure, water in fuel. Hourmeter and road speed indicator, engine temperature, fuel gauge, clock and inclinometer.

Mechanical joystick, direct acting hydraulic control levers. Adjustable steer column with stalk bar powershift change and forward reverse shuttle. Throttle and brake pedal. Adjustable deluxe seat with adjacent park brake fitted.

Automatic eye level audio-visual load moment indicator warning system receiving a signal from a load sensor on the rear axle.

This system continuously monitors the machine's forward stability and leaves the operator in control at all times.

Safety canopy as above but with side glass only (screen wiper and heater/screen demister not applicable).

Operator presence switch in seat (Stage IIIb machines).

*Adaptive Load Control for EU territories conforms to EN15000.

STEERING

Hydrostatic power steering with power track rods on both axes.

Three steer mode options: front wheel steer; all wheel steer; crab steer: operated from in the cab by a selection switch.

OPTIONS AND ACCESSORIES

Options: Front and rear working lights, rotating flashing beacon, fire extinguisher, traction and industrial tyres, electrical 2/4WD select, limited slip differential in front axle, windscreen and roof guard, air suspension seat, deluxe cab trim, roof and front screen blind, radio kit, air conditioning, reversing fan, deluxe trim, armrest (SLC only), roof moulding.

Single lever mechanical joystick, with push button extend and retract.

Attachments: Contact your local dealer for details of the comprehensive range.

A GLOBAL COMMITMENT TO QUALITY

JCB's total commitment to its products and customers has helped it grow from a one-man business into Britain's largest privately owned manufacturer of backhoe loaders, crawler excavators, wheeled excavators, telescopic handlers, wheeled loaders, dump trucks, rough terrain fork lifts, industrial fork lifts, mini/midi excavators, skid steer loaders, tractors and compaction equipment.

By making constant and massive investments in the latest production technology, the JCB factories have become some of the most advanced in the world.

By leading the field in innovative research and design, extensive testing and stringent quality control, JCB machines have become renowned all over the world for performance, value and reliability.

And with a global sales and service network of more than 650 dealers and agents, we aim to deliver the best customer support in the industry.

Through setting the standards by which others are judged, JCB has become one of the world's most impressive success stories.



JCB Sales Limited, Rokester, Staffordshire ST14 5JP. Tel: 01889 590312. Web: <http://www.jcb.com>

JCB reserves the right to change specifications without notice. Illustrations shown may include optional equipment and accessories. The JCB logo is a registered trademark of J C Bamford Excavators Ltd.



9999/4952 06/13 Issue 9 (T4)