

Bobcat® S70 Skid-Steer Loader

Specifications

Performance	S70	
Rated Operating Capacity	700 lb. (318 kg) ¹	
Tipping Load	1415 lb. (642 kg)	
Hydraulic Pump Capacity	9.8 gpm (37.8 L/min.)	
Travel Speed	6.1 mph (9.8 km/hr.)	
Operating Weight	2845 lb. (1291 kg)	
Dimensions		
Length (with bucket)	100.8 in. (2560 mm)	
Width (with bucket)	36.0 in. (914 mm)	
Height	71.4 in. (1814 mm)	
Height to Bucket Pin	94.5 in. (2399 mm)	
Engine		
Model	D1005-E	
Fuel/Cooling	Diesel/Liquid	
Cylinders	3	
SAE HP/Displacement	23.5/61.1 cu. in. (1.0 L)	
Fuel Tank Capacity	6.5 gal. (24.6 L)	
Operation		
Steering and Drive	Forward, reverse, travel speed and steering controlled by two hand levers.	
Hydraulics	Raise/lower lift arms and dump/rollback bucket controlled by two foot pedals.	
Transmission	Hydrostatic, four-wheel drive.	
Standard Features		
5.70-12 Standard Tires	Meters/Gauges/	Bob-Tach™
Bobcat Interlock Control System (BICS™)	Warning Lights	Operator Cab
Front & Rear Lights	Parking Brake	Rear Window
Front Auxiliary Hydraulics	Seat Bar	Seat Belt
High Back	Seat Belt	Spark Arresting System
Cushion Seat		
Lift Arm Support		
Options/Accessories		
Attachment Control Kit	Side Windows Kit	Backup Alarm
Bobcat Heavy-Duty Tires	Single-Point Lift Kit	Cab Enclosure
Cab Heater	Skid-Steer Loader Training Kit	Cab Enclosure
Catalytic Purifier	Sound Cab (reduces noise)	Cab Heater
Horn	Special Applications Kit ³	Catalytic Purifier
Hydraulic Bucket Positioning ²	Strobe/Rotating Beacon Lights	Horn
Keyless Start Kit	Suspension Seat	Hydraulic Bucket Positioning ²
Service Safety Training Course	Top Window	Keyless Start Kit
	Turf Tires	Service Safety Training Course

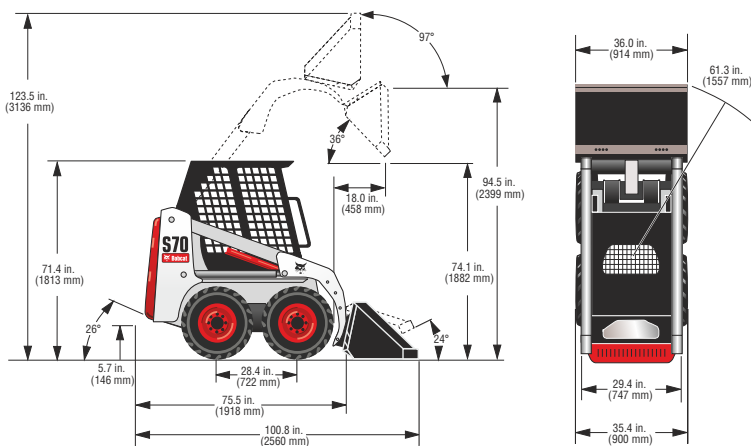

NOTE — Where applicable, dimensions are in accordance with Society of Automotive Engineers (SAE) and ISO standards. Specifications and design are subject to change without notice. Pictures of Bobcat loaders may show other than standard equipment. All dimensions are given for loader equipped with standard tires. All dimensions are shown in inches. Respective metric dimensions are enclosed by parentheses. Bobcat Company complies with the requirements of ISO 9001 as registered with BSI.

Bobcat S70... the loader for tough jobs in tight spots.

The compact Bobcat S70 skid-steer loader is small enough to get in the tight spots, yet tough enough to get you out.

This agile little workhorse is only 6 feet tall and 3 feet wide — the ideal size for scooting through narrow doorways, corridors, aisles, alleys and gates, and for working under low ceilings.

It's the perfect loader whenever the job is too big for a shovel or the space is too small for a larger machine — in backyards, barns, construction sites and demolition areas.

And versatile? You bet. With more than 20 Bobcat attachments to choose from, the S70 is a multi-attachment carrier that's ready to take on just about any job.

Plus — you get to do your work in the comfort and safety of the S70's operator-friendly, FOPS/ROPS-approved cab (Falling Object Protective Structure and Roll-Over Protective Structure). You'll also appreciate the comfortable high-back seat, low noise and easy entry and exit.

The S70 gives you 700 pounds of rated operating capacity and a rugged 23.5 horsepower liquid-cooled diesel engine that powers the hydrostatic 4-wheel drive.

Like all Bobcat loaders, the S70 allows quick, easy access to hydrostatic, hydraulic and engine systems, thanks to the swing-out tailgate and tip-up cab.

All this, and an excellent warranty, too. Check out the compact S70 skid-steer loader at your Bobcat dealer's showroom. It's the loader that's small in size, small in price, but big in value, comfort, performance and versatility!

700 LB.
Rated Operating Capacity

9.8 GPM
Hydraulic Flow

23.5 HP
Liquid-Cooled Diesel Engine

¹Operating capacity rated with standard digging bucket according to SAE standard J818. OPERATING CAPACITY TO EQUAL NO MORE THAN ONE HALF THE TIPPING LOAD.

²Bucket positioning helps operator keep the same tilt of the load during lifting.

³Includes polycarbonate front door, top and rear windows.

⁴Special application kit (see #3) must be used.

- A - 5.70 x 12 Tires - 35.4 in. (900 mm)
23 x 8.50 - 12 Tires - 43.3 in. (1100 mm)
- B - 5.70 x 12 Tires - 29.4 in. (747 mm)
23 x 8.50 - 12 Tires - 34.8 in. (884 mm)
- C - 36 in. Bucket Width - 36.0 in. (914 mm)
44 in. Bucket Width - 44 in. (1118 mm)

Specifications and design are subject to change without notice. Pictures of Bobcat products may show other than standard equipment.

Bobcat Attachments for this model:

- Angle Broom
- Auger
- Backhoe
- Boring Unit
- Breaker⁴
- Bucket
- Combination Bucket
- Digger
- Dumping Hopper
- Grapple, Industrial
- Grapple, Root
- Grapple, Utility (for use with utility fork or bucket)
- Landplane
- Mini Scraper
- Pallet Fork
- Scraper
- Snowblower*
- Snow Blade
- Snow V-Blade*
- Soil Conditioner
- Stump Grinder
- Sweeper
- Tiller
- Tree Fork
- Trencher
- Utility Blade
- Utility Fork
- Utility Frame
- V-Blade
- Vibratory Plow



S70 Skid-Steer Loader

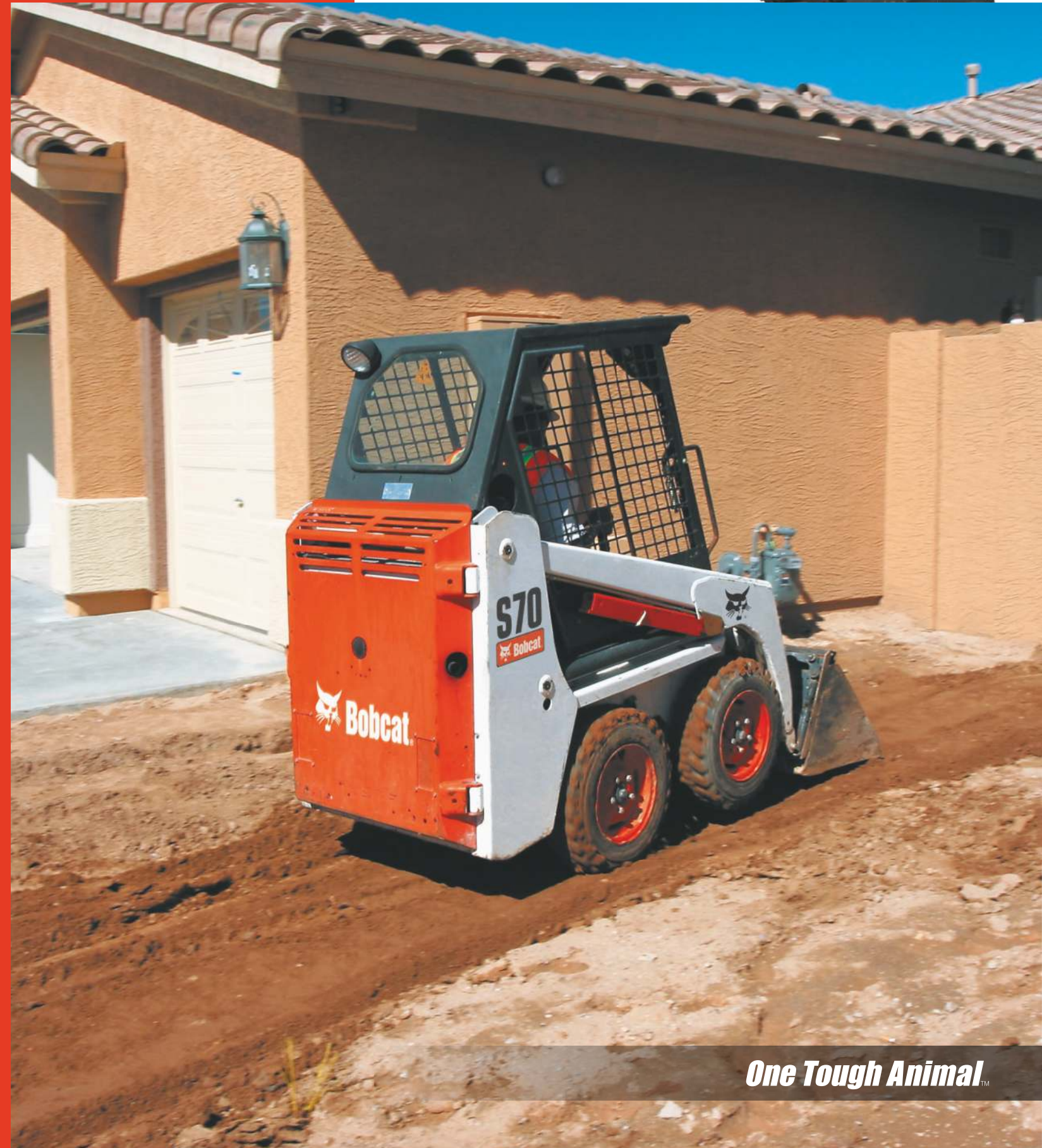

One Tough Animal™



Doosan Bobcat India Pvt. Ltd.,
6th Floor, HTC Towers, No.41, GST Road, Guindy, Chennai - 600 032, India.
☎ +91 96000 04852 ✉ bobcatindia@doosan.com

*Attachment Control Kit required.

Bobcat S70...the biggest little loader on the market!

The compact Bobcat® S70 skid-steer loader is the versatile attachment carrier that out-works, out-digs everything in its class.

- 700 lb. Rated Operating Capacity
- 9.8 GPM Hydraulic Flow
- 23.5 hp Liquid-Cooled Diesel Engine

Big performance in a small package!

The S70 loader makes compactness a virtue. It goes where bigger machines can't go. It's high in value. It's easily transportable. Yet it's also dependable, agile, productive, labor-saving, operator-friendly — and is equipped with a cab that offers many of the comforts of a much larger machine!

But most of all, the S70 is versatile. With a choice of over 20 hard-working Bobcat attachments, you and your S70 can tackle just about any job with ease and confidence.

Hook Up to These Job-Matched Bobcat Attachments



Angle Broom

Sweeps snow, dirt and debris from driveways, loading docks and warehouse floors.



Auger

Drills holes with speed and plumb-line accuracy.



Snowblower

Powerful snow mover. Discharge chute is controlled from operator's seat.



Mini Scraper

Cleans ice and snow off parking lots; scrapes floors; removes tile flooring.



Backhoe

Converts loader into a digging machine. Digging depths up to 5.5 ft.



Breaker

Breaks up concrete and asphalt quickly and effortlessly.



Tiller

Digs and loosens soil; mixes compost and other materials into existing soil.



Trencher

Handles a wide range of jobs, including trenching close to buildings.



Buckets

There's a bucket for every job, from digging to dumping.



Dumping Hopper

Loads quickly and saves time by hauling more material in fewer trips to the dumpsite.



Utility Blade

Use it as both a snow blade or dozer blade. Curved moldboard angles 30 degrees.



Utility Fork

Grabs bulky, hard-to-handle material: loose hay, bedding, manure and bundled items.



Landplane

Removes large clods and rocks, breaks up hard ground, sorts debris from soil.



Pallet Fork

Handles palletized material on farms, construction jobs and industrial sites.



Utility Grapple

Handles loose hay, straw, manure, bales and hard-to-grasp material. Use it with bucket or utility fork.



Standard BOB-TACH™ Mounting System Assures Fast, Secure Attachment Changes!



Turf tires are also available.

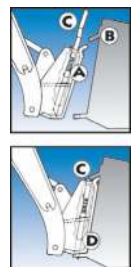

Exclusive Bob-Tach™ System.

For fast, secure attachment changes. Bob-Tach frame (A) moves into attachment flange (B) handle (C) pushes down easily, pressing wedge (D) through frame and attachment hole for solid connection.

Adjustment Not Needed.

The Bobcat "bow-tie" drive chain design uses pre-stressed, heavy-duty drive chains in two short continuous loops on each side. That means no periodic, time consuming adjustments, plus long life even in the most rugged conditions.



Bearing Grease? Forget It!

Self-lubricating axle bearings never need greasing. The unique hub design offers great seal protection.

Training Resources.

Training kits, available through your Bobcat dealer's parts department, let you train current and new operators and service technicians on the latest safety operation and servicing functions for Bobcat skid-steer loaders. A Spanish language version is also available. Check the Bobcat website for more information: www.bobcat.com



Serviceability.

Bobcat skid-steer loaders feature easy servicing and quick access to components should repairs be needed. Service technicians can get to hydraulic/hydrostatic components quickly by unbolting two nuts and lifting the cab back. The tailgate swings out — allowing fast, easy access to engine components.



Belt Drive Advantage.

The Bobcat belt drive advantage means Bobcat loader engines can be run slower, resulting in a quieter machine that lasts longer and uses less fuel. This system also maximizes pump efficiency and minimizes steering lever effort. Ask about the 3-year belt warranty!

